

INFORMATION SHEET FOR WRAP AROUND CASE PACKER APPLICATIONS
 USE SEPARATE SHEET FOR EACH PACKAGE SIZE OR PACKAGING ARRANGEMENT

- POSITION NUMBER OF PACKAGE AS IT FEEDS TO PACKER
- HOW MANY LANES FEEDING?
- PRODUCTION RATE PER LANE (PACKAGES PER MINUTE)
- MAXIMUM CASES PER MINUTE
- WEIGHT OF FILLED CASE?
- IS CUSTOMER WILLING TO CHANGE PACK ARRANGEMENT?

METHOD OF SEALING:

- HOT MELT (STANDARD)
- OTHER _____

PROGRAMMABLE CONTROLLER:

- A-B MICROLOGIX 1500 (STANDARD)
- OTHER _____

CHANGEOVER:

HOW OFTEN WILL THE MACHINE BE CHANGED OVER?
 _____ TIMES PER _____

ENVIRONMENT:

- NEMA 12 (NON-WASHDOWN)
- NEMA 4X (WASHDOWN)

IF PADS ARE REQUIRED, WHAT ARE THEY MADE OF?

- CORRUGATED
- CHIPBOARD
- OTHER _____

PLACEMENT?

- VERTICALLY
- HORIZONTALLY

PACKAGE CONTENTS _____
 WT. PER PACKAGE _____

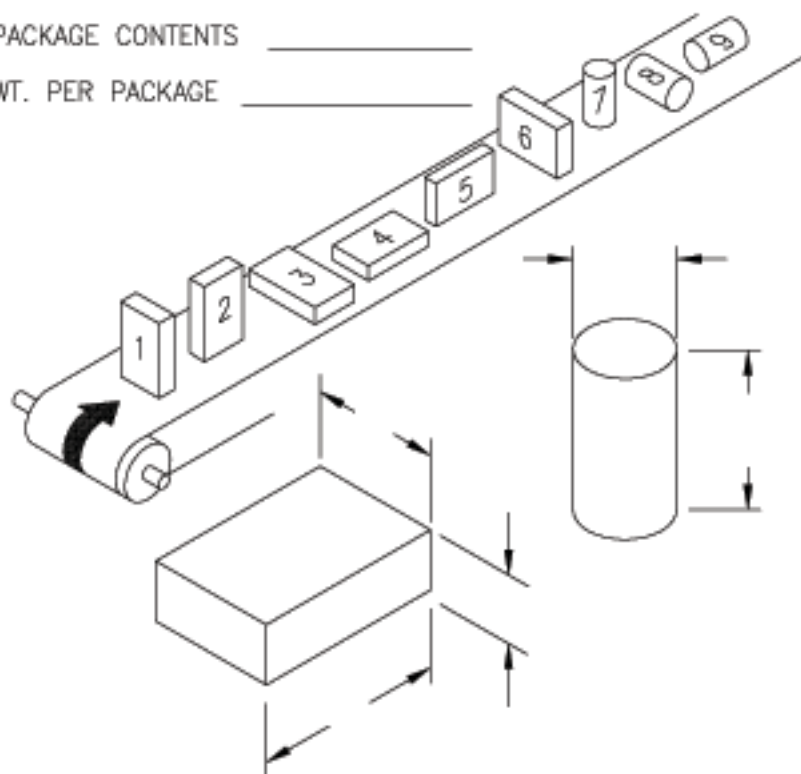

SKETCH PACK & WRITE IN DIMENSIONS ON CASE

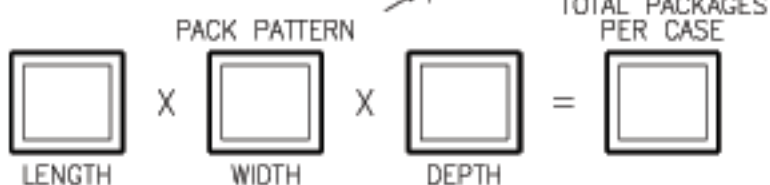
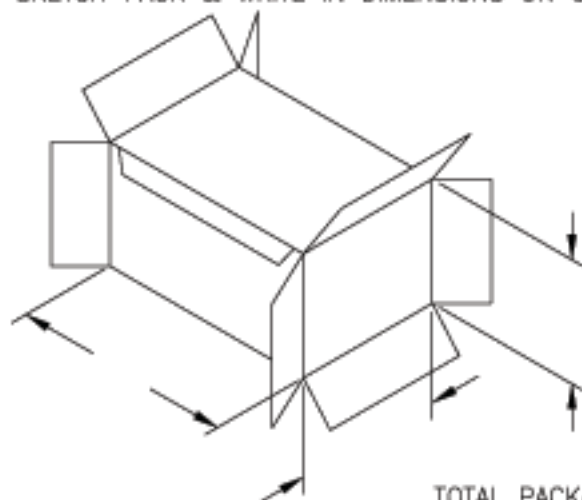

CUSTOMER:

REPRESENTATIVE:

TODD DICE



T.A.D. PACKAGING MACHINERY, INC.
 10759 CIVIC CENTER DRIVE
 RANCHO CUCAMONGA, CA 91730
 PHONE (909) 476-0503 / FAX (909) 476-0573
 WWW.TADPACKAGING.COM SALES@TADPACKAGING.COM

